



## Product Specification

<b>Customer</b>	
<b>Model Name</b>	Z035NC111
<b>Description</b>	Standard LCD Module 320(RGB)x240 Dots 3.5" TFT LCD
<b>Date</b>	2015/10/22
<b>Version</b>	V1.0

<b>Customer Approval</b>	
<b>Date</b>	
The above signature represents that the product specifications, testing regulation, and warranty in the specifications are accepted	

<b>Engineering</b>			
<b>Check</b>	<b>Date</b>	<b>Prepared</b>	<b>Date</b>



## Table of Contents

1. Record of Revision.....	3
2 .General Specifications.....	4
3 .Input/Output Terminals.....	5
4. Absolute Maximum Ratings.....	6
5 .Electrical Characteristics.....	6
6 .Interface Timing.....	8
7. Optical Characteristics.....	12
8 . Environmental / Reliability Tests.....	16
9. Mechanical Drawing.....	17
1 0.Packing.....	21
11. Precautions For Use of LCD modules.....	22



### 1.Record of Revision

Rev	Issued Date	Description	Editor
1.0	2015.10.22	First Release.	KING Liang



## 2 General Specifications

	Feature	Spec
Characteristics	Size	3.5inch
	Resolution	320(horizontal)*240(Vertical)
	Interface	Digital 24-bit RGB/SERIAL RGB/CCIR656/CCIR601
	Connect type	Connector
	Color Depth	16.7M
	Technology type	a-Si
	Pixel pitch (mm)	0.073 x 0.219
	Pixel Configuration	R.G.B. Vertical Stripe
	Display Mode	Normally White
	Driver IC	HX8238D
	Surface Treatment	HC
	Viewing Direction	12 O'clock
Mechanical	LCM (W x H x D) (mm)	76.90*63.9*3.26
	Active Area(mm)	70.08 x 52.56
	With /Without TSP	Without TSP
	Weight (g)	TBD
	LED Numbers	6 LEDs

Note 1: Viewing direction is following the data which measured by optics equipment.

Note 2: Requirements on Environmental Protection: RoHS

Note 3: LCM weight tolerance: +/- 5%



### 3 Input/Output Terminals

No.	Symbol	Description
1,2	VBL-	Backlight LED Cathode
3,4	VBL+	Backlight LED Anode.
5	YU	Touch panel up side
6	XR	Touch panel right side
7	NC	NC
8	RESET	Reset Signal pin ("Low" is enable)
9	SPENB	Chip select
10	SPCK	Serial Clock.
11	SPDA	Serial Data
12-19	B0~B7	Data bus
20-27	G0~G7	Data bus
28-35	R0~R7	Data bus
36	HSYNC	Line Synchronous Signal
37	VSYNC	Frame Synchronous Signal
38	DOTCLK	Dot-clock signal and oscillator source
39-40	NC	NC
41-42	VDD	Power supply for logic operation
43	YD	Touch panel bottom side
44	XL	Touch panel left side
45-47	NC	
48	SEL2	Control the input data format/floating
49	SEL1	Control the input data format
50	SEL0	Control the input data format
51	NC	NC
52	DEN	Display enable signal
53-54	GND	System Ground



**SEL2-0:** Define the input interface mode.

SEL2	SEL1	SEL0	Format	Operating Frequency
0	0	0	Parallel-RGB data format (only support stripe type color filter)	6.5MHz
0	0	1	Serial-RGB data format	19.5MHz
0	1	0	CCIR 656 data format (640RGB)	24.54MHz
0	1	1	CCIR 656 data format (720RGB)	27MHz
1	0	0	YUV mode A data format (Cr-Y-Cb-Y)	24.54MHz
1	0	1	YUV mode A data format (Cr-Y-Cb-Y)	27MHz
1	1	0	YUV mode B data format (Cb-Y-Cr-Y)	27MHz
1	1	1	YUV mode B data format (Cb-Y-Cr-Y)	24.54MHz

Mode	D[23:16]	D[15:8]	D[7:0]	IHS	IVS	DEN
ITU-R BT 656	D[23:16]	GND	GND	NC	NC	NC
ITU-R BT 601	D[23:16]	GND	GND	IHS	IVS	NC
8 bit RGB	D[23:16]	GND	GND	IHS	IVS	NC for HV Mode DEN for DEN Mode
24 bit RGB	R[7:0]	G[7:0]	B[7:0]	IHS	IVS	NC for HV Mode DEN for DEN Mode

## 4 Absolute Maximum Ratings

Item	Symbol	MIN	MAX	Unit	Remark
Supply Voltage	V <sub>DD</sub>	-0.5	5.0	V	
Operating Temperature	T <sub>OPR</sub>	-20	70	°C	
Storage Temperature	T <sub>STG</sub>	-30	80	°C	

## 5 Electrical Characteristics

### 5.1 Operating conditions:

Parameter	Symbol	Rating			Unit	Condition
		Min.	Typ.	Max.		
Power Voltage	VCC	3.0	3.3	3.6	V	
Digital Operation Current	I <sub>CC</sub>	-	8.6	-	mA	
Gate On Power	V <sub>GH</sub>	-	13.9	-	V	
Gate Off Power	V <sub>GL</sub>	-	-13.6	-	V	
Vcom High Voltage	V <sub>comH</sub>	-	3.9	-	V	Note1
Vcom low Voltage	V <sub>comL</sub>	-	-1.2	-	V	Note1
Vcom level max	V <sub>comA</sub>	-	-	6	V	

Note1. VcomH& VcomL : Adjust the color with gamma data. Vp-p should be higher then 4V.(Option 5V)  
 Note: Please power on following the sequence VCC → VDD

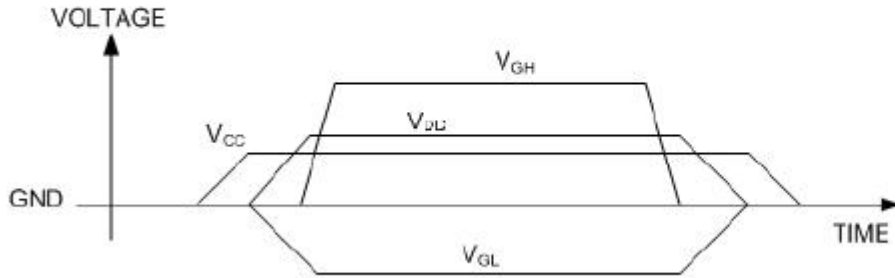

**5.2 Driving Backlight**

Item	Symbol	MIN	TYP	MAX	Unit	Remark
Forward Current	$I_F$	-	20	25	mA	
Forward Voltage	$V_F$	18.6	19.8	21	V	
Backlight Power consumption	$W_{BL}$	-	400	420	W	

Note 1: Each LED :  $I_F = 20\text{ mA}$ ,  $V_F = 3.2\text{V}$ .

Note 2: Optical performance should be evaluated at  $T_a = 25^\circ\text{C}$  only.

Note 3: If LED is driven by high current, high ambient temperature & humidity condition. The life time of LED will be reduced. Operating life means brightness goes down to 50% initial brightness. Typical operating life time is estimated data.

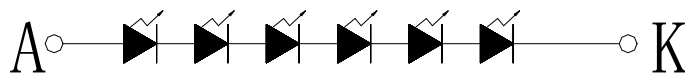

CURRENT  $I_F = 20\text{mA}$

Figure : LED connection of backlight

**5.3 Block Diagram**

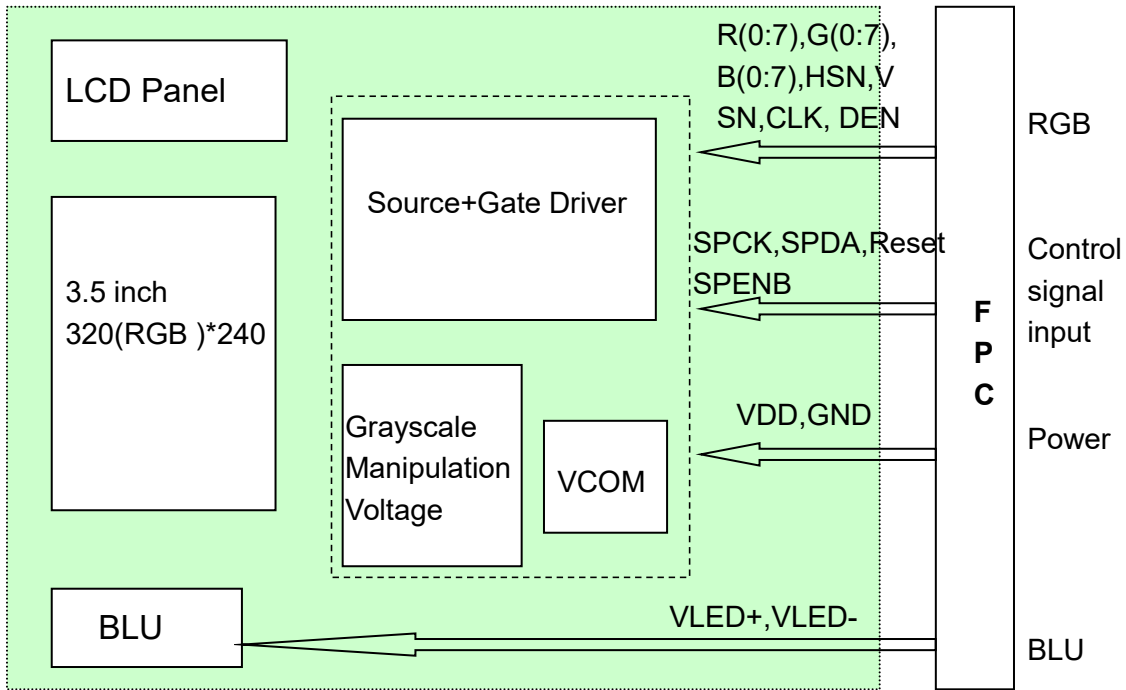

## 6 Interface Timing

### 6.1 AC Electrical Characteristics





**Digital Parallal RGB interface**

Signal	Item	Symbol	Min	Typ	Max	Unit
Dclk	Frequency	Tosc	-	156	-	ns
	High Time	Tch	-	78	-	ns
	Low Time	Tcl	-	78	-	ns
Data	Setup Time	Tsu	12	-	-	ns
	Hold Time	Thd	12	-	-	ns
Hsync	Period	TH	-	408	-	Tosc
	Pulse Width	THS	5	30	-	Tosc
	Back-Porch	Thb		38		Tosc
	Display Period	TEP	-	320	-	Tosc
	Hsync-den time	THE	36	68	88	Tsoc
	Front-Porch	Thf	-	20	-	Tosc
Vsync	Period	Tv	-	262	-	TH
	Pulse Width	Tvs	1	3	5	TH
	Back-Porch	Tvb	-	15	-	TH
	Display Period	Tvd	-	240	-	TH
	Front-Porch	Tvf	2	4	-	TH

- Note:
1.  $T_{hp} + T_{hb} = 68$ , the user is make up by yourself.
  2.  $T_v = T_{vs} + T_{vb} + T_{vd} + T_{vf}$ , the user is make up by yourself.
  3. When SYNC mode is used, 1<sup>st</sup> data start from 68<sup>th</sup> Dclk after Hsync falling



**Digital Serial RGB interface**

Signal	Item	Symbol	Min	Typ	Max	Unit
Dclk	Frequency	Tosc	-	52	-	ns
	High Time	Tch	-	78	-	ns
	Low Time	Tcl	-	78	-	ns
Data	Setup Time	Tsu	12	-	-	ns
	Hold Time	Thd	12	-	-	ns
Hsync	Period	TH	-	1224	-	Tosc
	Pulse Width	THS	5	90	-	Tosc
	Back-Porch	Thb		114		Tosc
	Display Period	TEP	-	960	-	Tosc
	Hsync-den time	THE	108	204	264	
	Front-Porch	Thf	-	60	-	Tosc
Vsync	Period	Tv	-	262	-	TH
	Pulse Width	Tvs	1	3	5	TH
	Back-Porch	Tvb	-	15	-	TH
	Display Period	Tvd	-	240	-	TH
	Front-Porch	Tvf	2	4	-	TH

- Note:
1.  $T_{hp} + T_{hb} = 204$ , the user is make up by yourself.
  2.  $T_v = T_{vs} + T_{vb} + T_{vd} + T_{vf}$ , the user is make up by yourself.
  3. When SYNC mode is used, 1<sup>st</sup> data start from 204<sup>th</sup> Dclk after Hsync falling

**CCIR601/656 Interface**

Signal	Item	Symbol	Min	Typ	Max	Unit
Dclk	Frequency	Tosc	-	37	-	ns
	High Time	Tch	-	78	-	ns
	Low Time	Tcl	-	78	-	ns
Data	Setup Time	Tsu	12	-	-	ns
	Hold Time	Thd	12	-	-	ns

### 6.2 DC Electrical Characteristics

Parameter	Symbol	Rating			Unit	Condition
		Min.	Typ.	Max.		
Low level input voltage	$V_{IL}$	0	-	0.3 VCC	V	
High level input voltage	$V_{IH}$	0.7 VCC	-	VCC	V	

### 6.3 Waveform

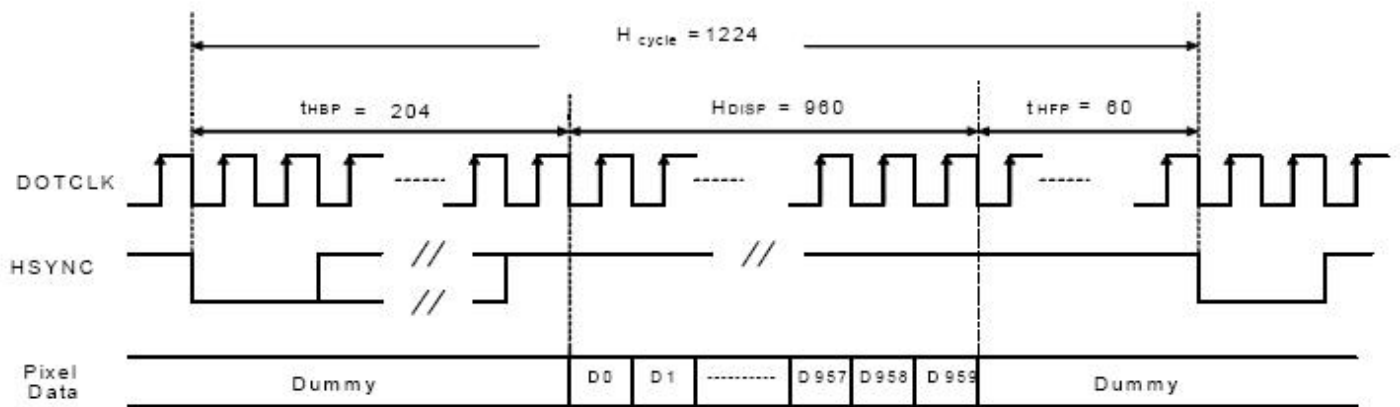

a) Horizontal Data Transaction Timing

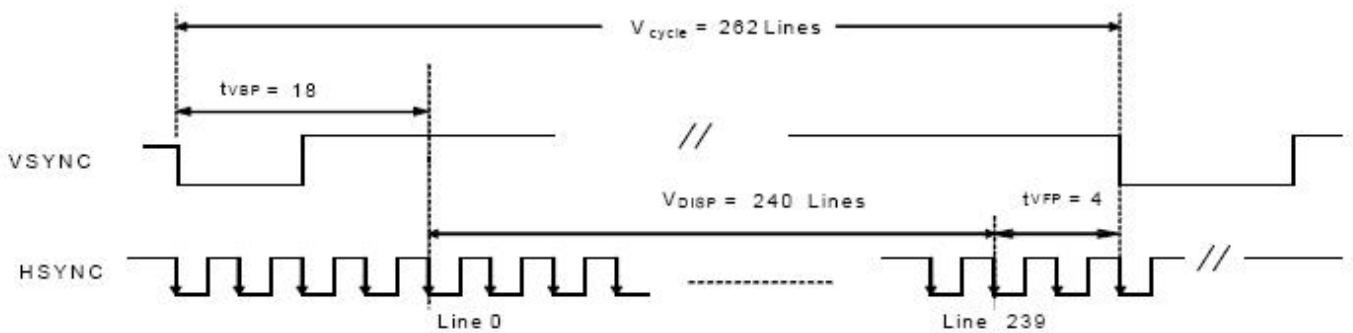

b) Vertical Data Transaction Timing

**Figure 3 Data Transaction Timing in Serial RGB (8 bit) Interface (SYNC Mode)**

RGB Mode (960x240) Vertical Timing - NTSC

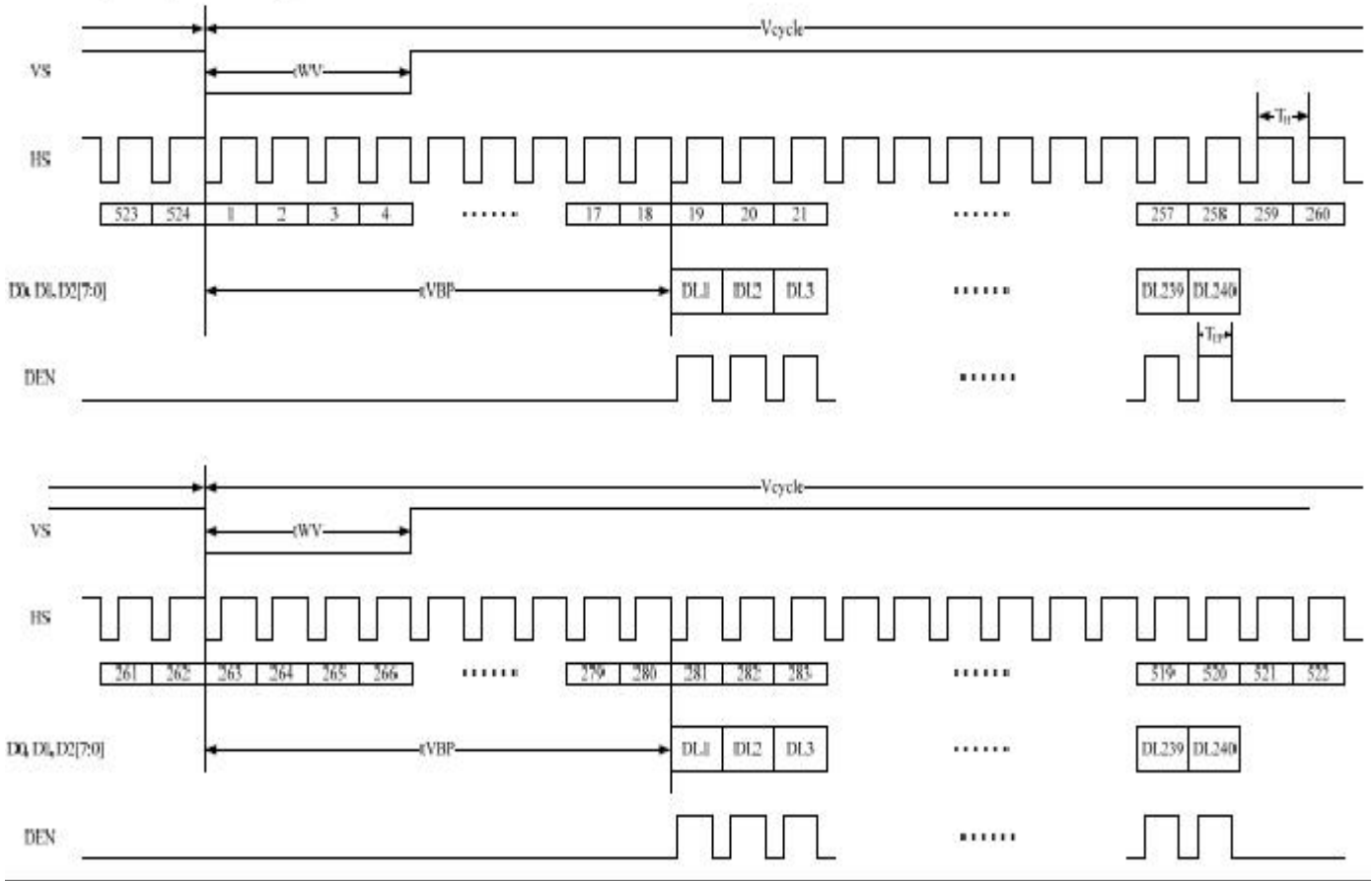
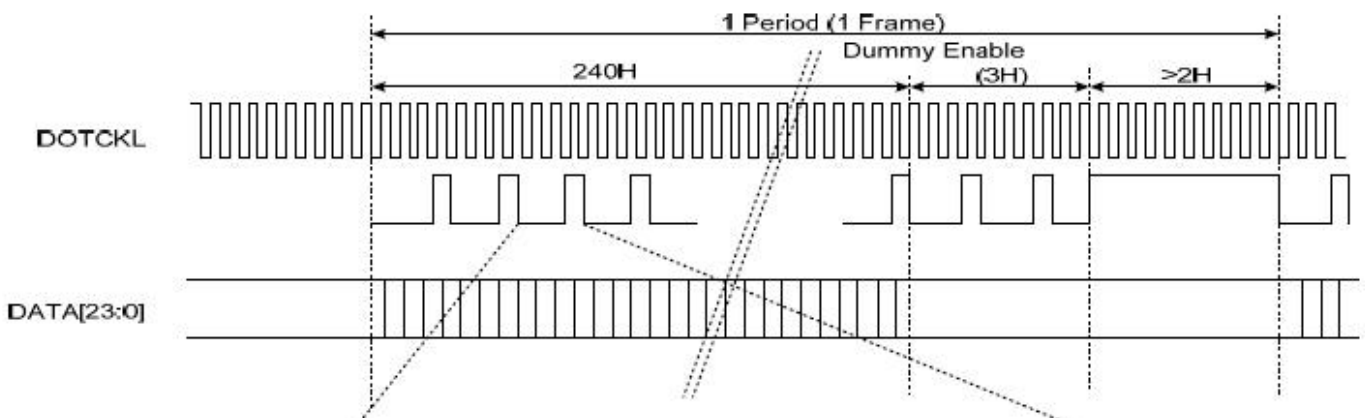

Figure 3 Digital RGB NTSC mode Vertical Data Format for 262T<sub>H</sub>



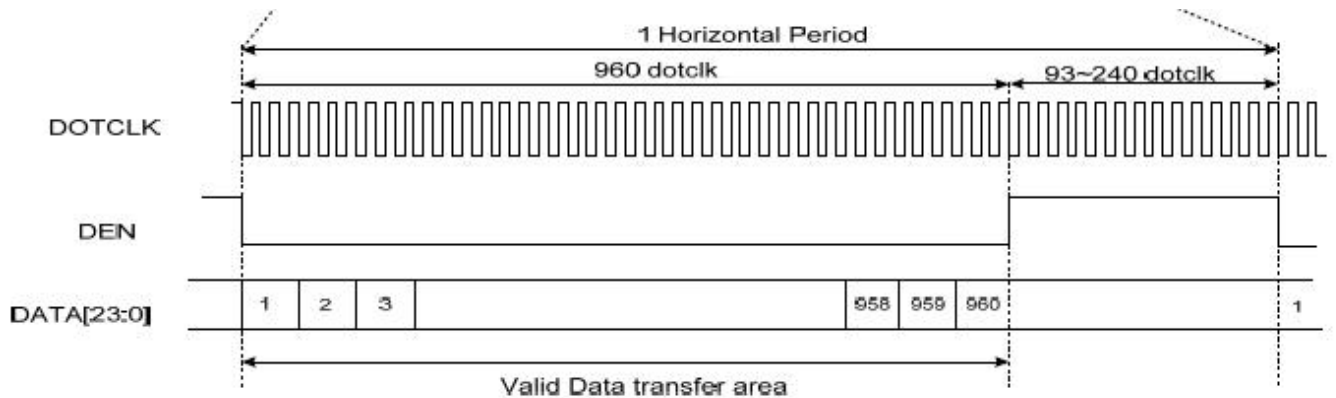
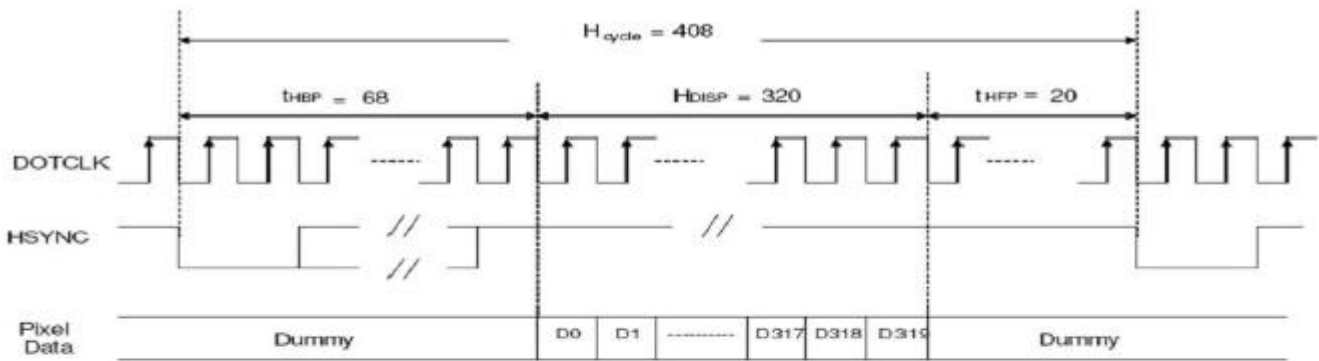
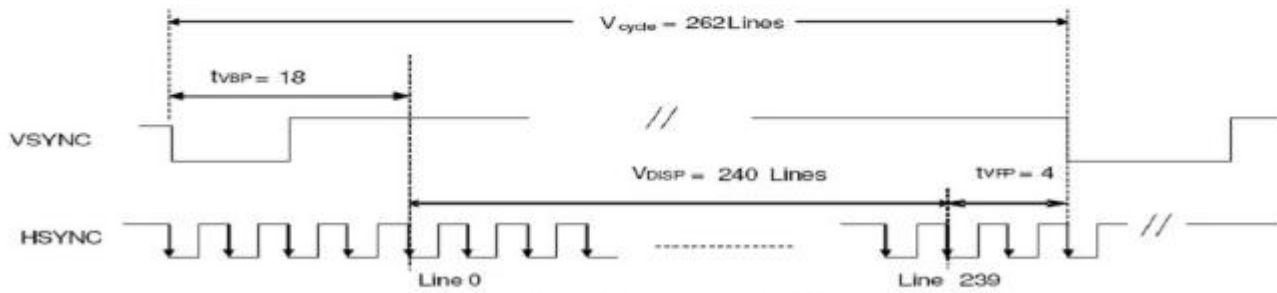

Figure 3 Data Transaction Timing in Serial RGB (8 bit) Interface (DE Mode)



a ) Horizontal Data Transaction Timing



b ) Vertical Data Transaction Timing

Figure 3 Data Transaction Timing in Parallel RGB (24 bit) Interface (SYNC Mode)

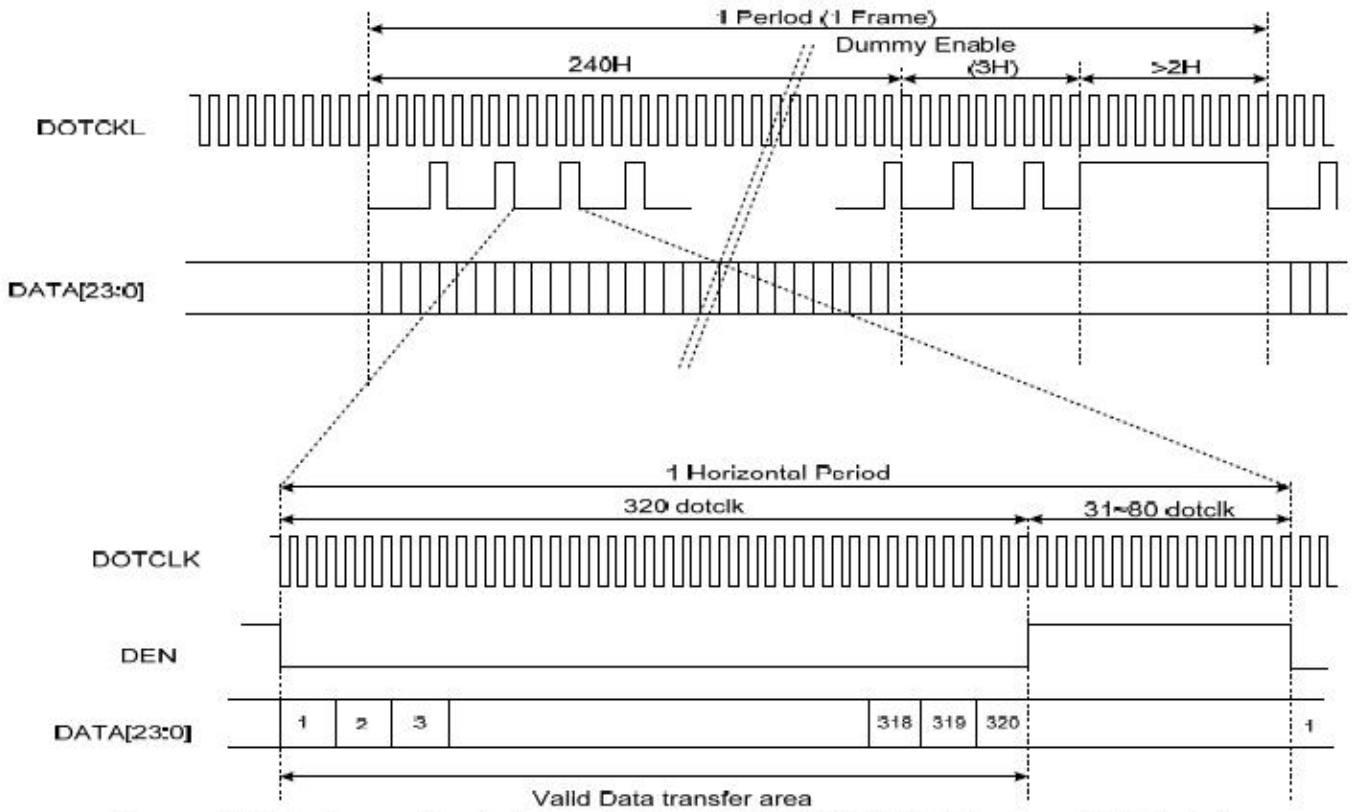

Figure 4 Data Transaction Timing in Parallel RGB (24 bit) Interface (DE Mode)

6.4 Clock and Sync waveforms

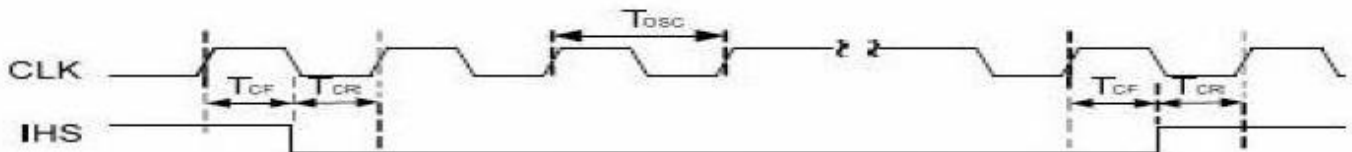

Figure 6 CLK and IHS timing waveform

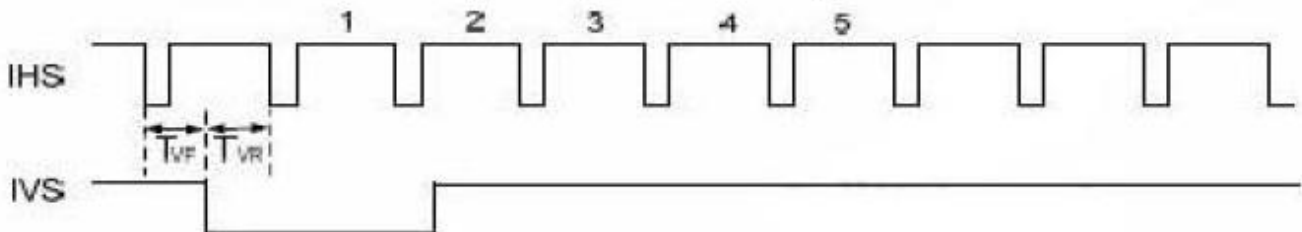
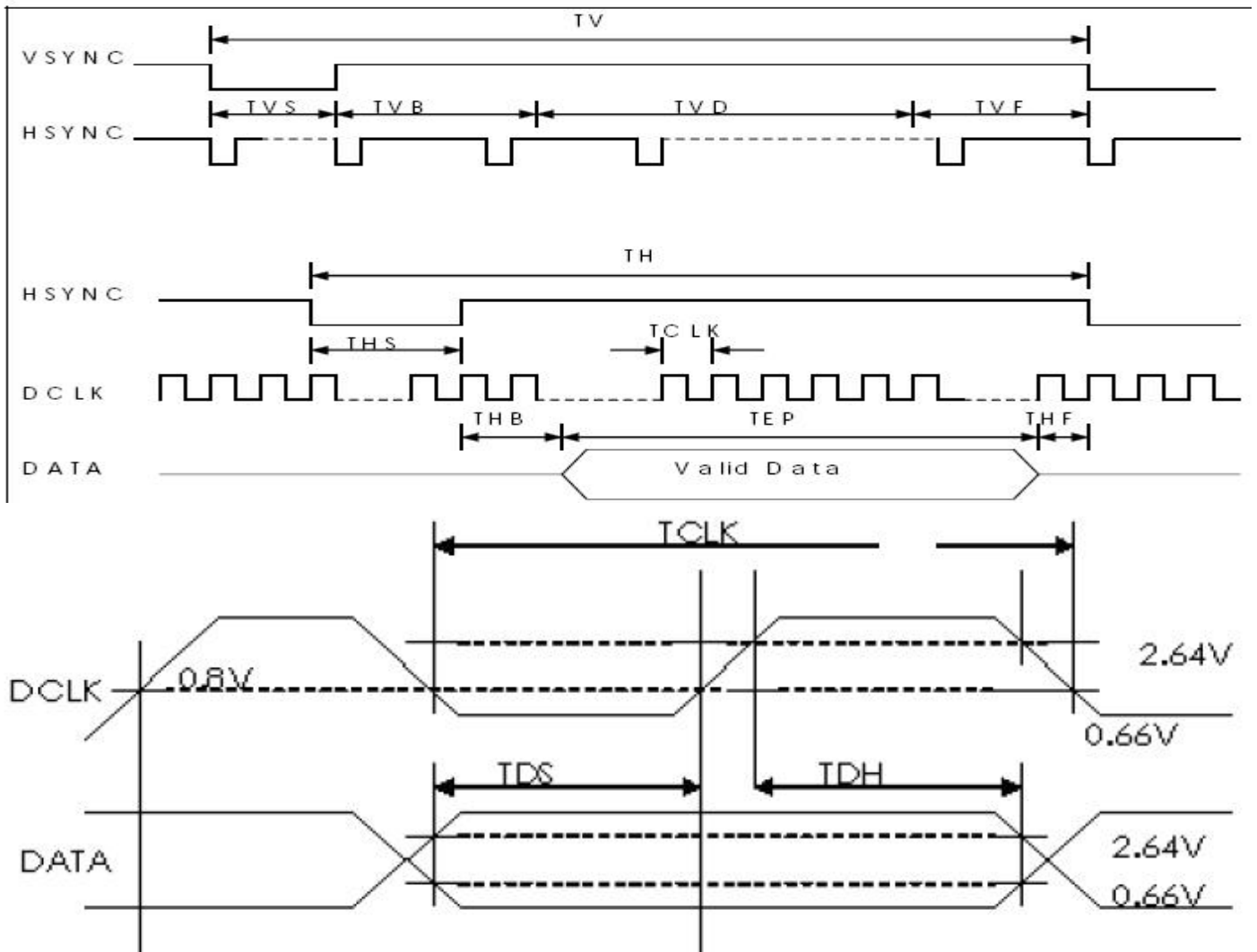
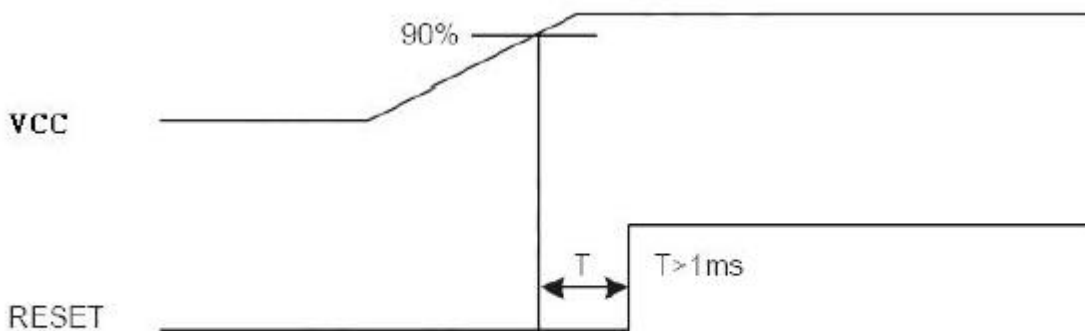

Figure 7 IHS and IVS timing waveforms



### 6.5 Reset Timing Chart

The RESET input must be held at least 1ms after power is stable



Reset timing



## 7 Optical Characteristics

Items	Symbol	Condition	Min.	Typ.	Max.	Unit	Remark	
Viewing angles	$\theta_T$	Center CR $\geq$ 10	40	55	-	Degree.	Note2	
	$\theta_B$		50	65	-			
	$\theta_L$		50	65	-			
	$\theta_R$		50	65	-			
Contrast Ratio	CR	$\Theta = 0$	20	300	-	-	Note1, Note3	
Response Time	$T_{ON}$	25°C	-	25	40	ms	Note1, Note4	
	$T_{OFF}$		-	25	40			
Chromaticity	White	Backlight is on	$X_W$	0.282	0.312	0.342	-	Note1, Note5
			$Y_W$	0.319	0.349	0.379	-	
	Red		$X_R$	0.609	0.639	0.669	-	
			$Y_R$	0.314	0.344	0.374	-	
	Green		$X_G$	0.264	0.294	0.324	-	
			$Y_G$	0.557	0.587	0.617	-	
	Blue		$X_B$	0.102	0.132	0.162	-	
			$Y_B$	0.106	0.136	0.166	-	
Uniformity	U		75	80	-	%	Note1, Note6	
NTSC				50		%	Note5	
Luminance	L		300	350			Note1, Note7	

Test Conditions:

1. IF= 20mA(one channel),the ambient temperature is 25°C.
2. The test systems refer to Note 1 and Note 2.

Note 1:Definition of optical measurement system.

The optical characteristics should be measured in dark room. After 5 minutes operation, the optical properties are measured at the center point of the LCD screen. All input terminals LCD panel must be ground when measuring the center area of the panel.



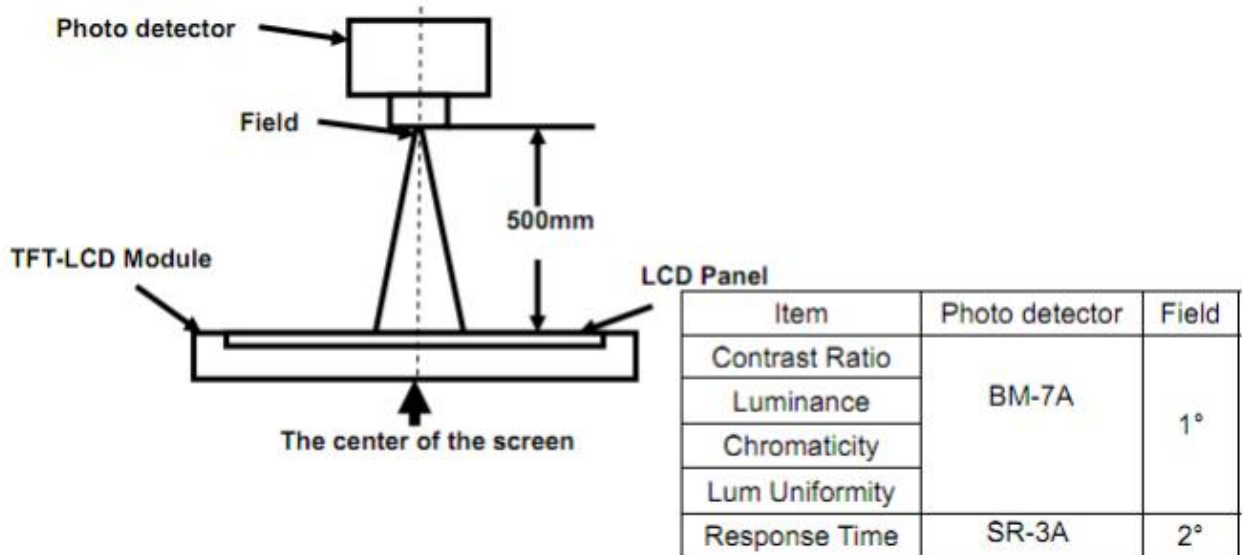

Note 2: Definition of viewing angle range and measurement system.  
viewing angle is measured at the center point of the LCD by CONOSCOPE(ergo-80).

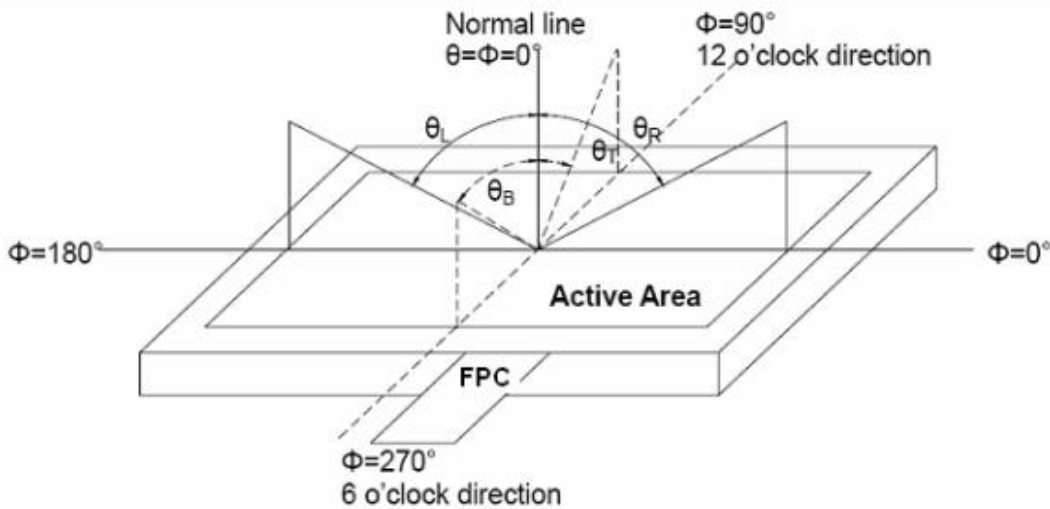

Fig. 1 Definition of viewing angle

Note 3: Definition of contrast ratio

$$\text{Contrast ratio (CR)} = \frac{\text{Luminance measured when LCD is on the "White" state}}{\text{Luminance measured when LCD is on the "Black" state}}$$

Note 4: Definition of Response time

The response time is defined as the LCD optical switching time interval between "White" state and

“Black” state. Rise time (TON) is the time between photo detector output intensity changed from 90% to 10%. And fall time (TOFF) is the time between photo detector output intensity changed from 10% to 90%.

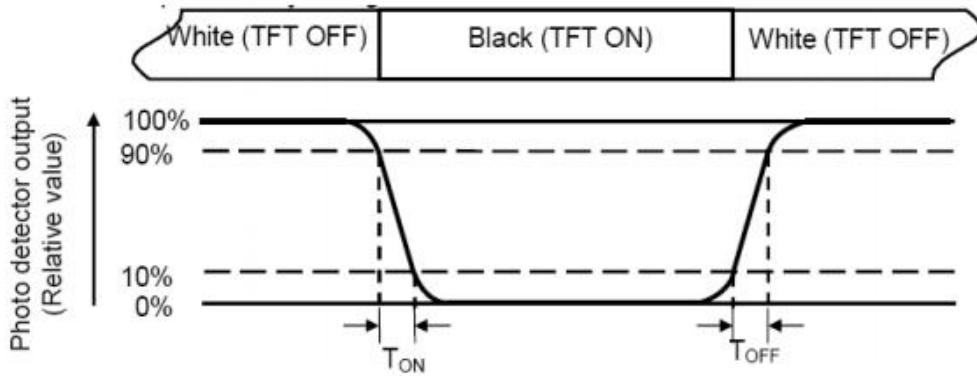

Note 5: Definition of color chromaticity (CIE1931)  
Color coordinates measured at center point of LCD.

Note 6: Definition of Luminance Uniformity

Active area is divided into 9 measuring areas (Refer Fig. 2). Every measuring point is placed at the center of each measuring area.

$$\text{Luminance Uniformity}(U) = \frac{L_{\min}}{L_{\max}} \times 100\%$$

L-----Active area length W----- Active area width

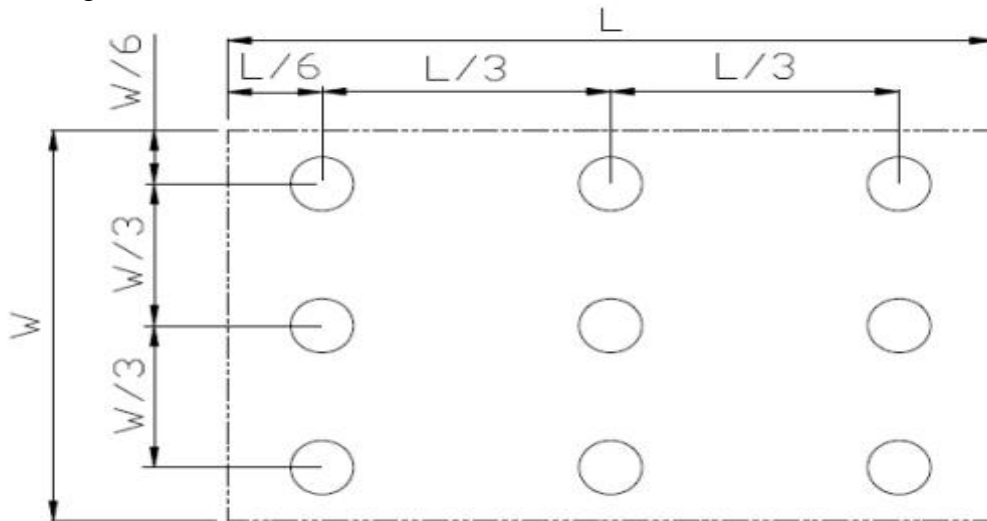

Fig. 2 Definition of uniformity

Lmax: The measured maximum luminance of all measurement position.

Lmin: The measured minimum luminance of all measurement position.

Note 7: Definition of Luminance :

Measure the luminance of white state at center point.



## 8 Environmental / Reliability Tests

No	Test Item	Condition	Remarks
1	High Temperature Operation	T <sub>s</sub> = +70°C, 240hrs	Note 1 IEC60068-2-2, GB2423. 2-89
2	Low Temperature Operation	T <sub>a</sub> = -20°C, 240hrs	Note 2 IEC60068-2-1 GB2423.1-89
3	High Temperature Storage	T <sub>a</sub> = +80°C, 240hrs	IEC60068-2-2 GB2423. 2-89
4	Low Temperature Storage	T <sub>a</sub> = -30°C, 240hrs	IEC60068-2-1 GB/T2423.1-89
5	High Temperature & Humidity Storage	T <sub>a</sub> = +60°C, 90% RH max, 160 hours	IEC60068-2-3 GB/T2423.3-2006
6	Thermal Shock (Non-operation)	-30°C 30 min ~ +80°C 30 min Change time: 5min, 30 Cycle	Start with cold temperature, end with high temperature IEC60068-2-14, GB2423.22-87
7	Electro Discharge (Operation) Static	C=150pF, R=330 Ω, 5 points/panel Air:±8KV, 5 times; Contact: ±4KV, 5 times; (Environment: 15°C ~ 35°C, 30% ~ 60%, 86Kpa ~ 106Kpa)	IEC61000-4-2 GB/T17626.2-1998
8	Vibration (Non-operation)	Frequency range: 10~55Hz, Stroke: 1.mm Sweep: 10Hz~55Hz~10Hz 2 hours for each direction of X .Y. Z. (package condition)	IEC60068-2-6 GB/T2423.5-1995
9	Shock (Non-operation)	60G 6ms, ± X, ±Y , ± Z 3 times for each direction	IEC60068-2-27 GB/T2423.5-1995
10	Package Drop Test	Height: 80 cm, 1 corner, 3 edges, 6 surfaces	IEC60068-2-32 GB/T2423.8-1995

Note: 1. T<sub>s</sub> is the temperature of panel's surface.  
2. T<sub>a</sub> is the ambient temperature of sample.



9 Mechanical Drawing

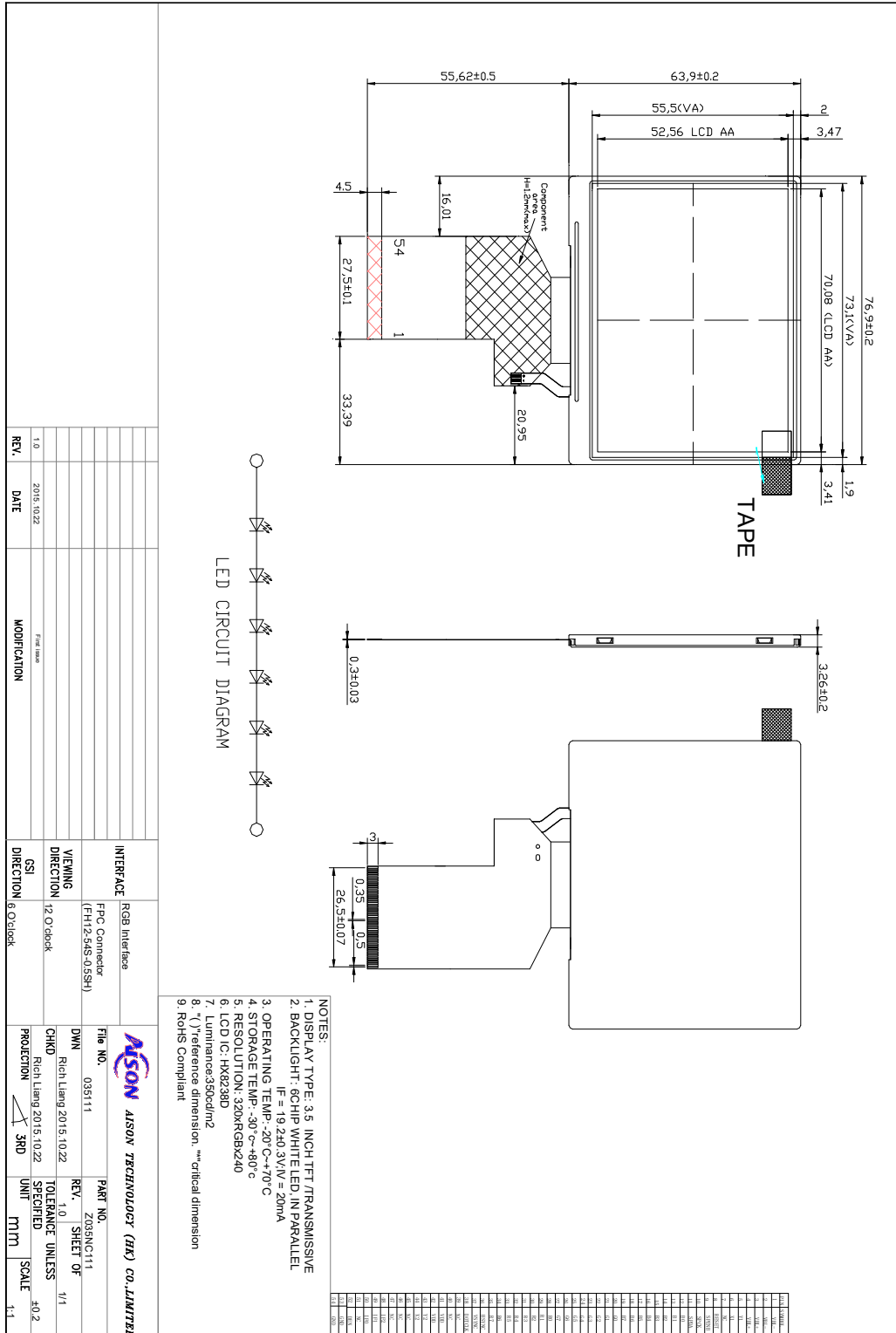

# 1 0.Packing

## Packing Method

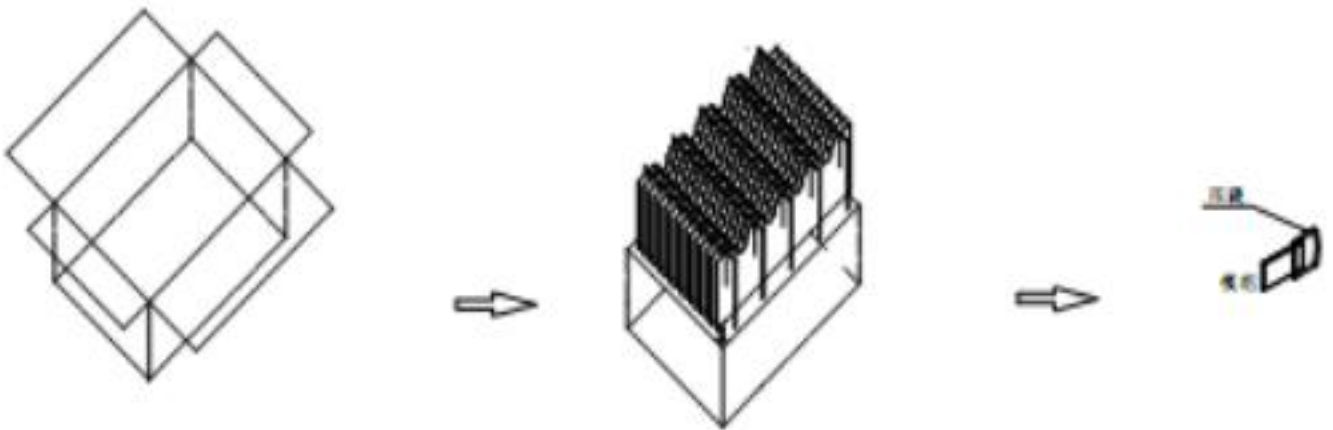

80 PCS

80\*2 PCS

160 PCS

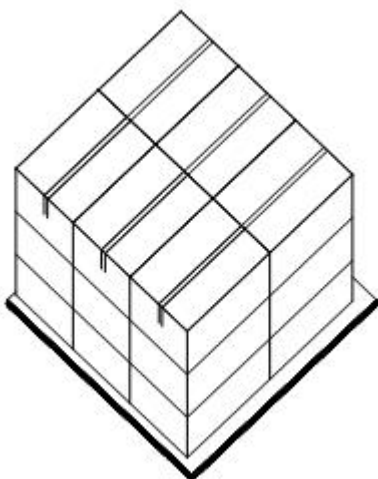
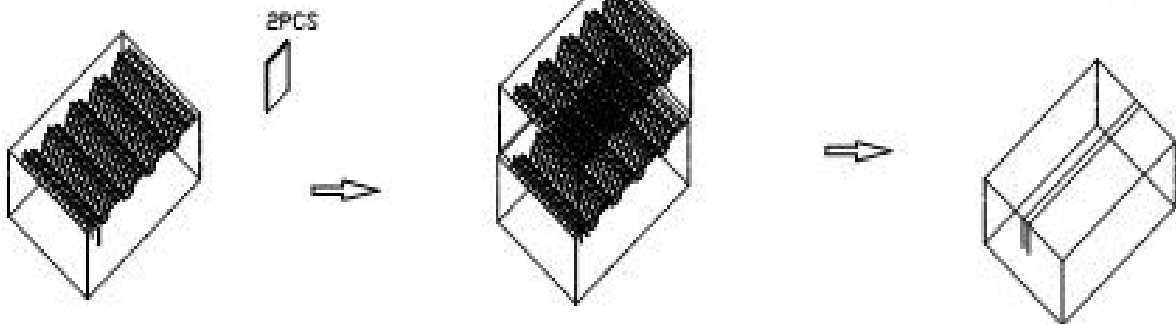



## 11. Precautions For Use of LCD modules

### 11.1 Handling Precautions

11.1.1. The display panel is made of glass. Do not subject it to a mechanical shock by dropping it from a high place, etc.

11.1.2. If the display panel is damaged and the liquid crystal substance inside it leaks out, be sure not to get any in your mouth, if the substance comes into contact with your skin or clothes, promptly wash it off using soap and water.

11.1.3. Do not apply excessive force to the display surface or the adjoining areas since this may cause the color tone to vary.

11.1.4. The polarizer covering the display surface of the LCD module is soft and easily scratched. Handle this polarizer carefully.

11.1.5. If the display surface is contaminated, breathe on the surface and gently wipe it with a soft dry cloth. If still not completely clear, moisten cloth with one of the following solvents:

- Isopropyl alcohol
- Ethyl alcohol

Solvents other than those mentioned above may damage the polarizer. Especially, do not use the following:

- Water — Ketone
- Aromatic solvents

11.1.6. Do not attempt to disassemble the LCD Module.

11.1.7. If the logic circuit power is off, do not apply the input signals.

11.1.8. To prevent destruction of the elements by static electricity, be careful to maintain an optimum work environment.

11.1.8.1. Be sure to ground the body when handling the LCD Modules.

11.1.8.2. Tools required for assembly, such as soldering irons, must be properly ground.

11.1.8.3. To reduce the amount of static electricity generated, do not conduct assembly and other work under dry conditions.

11.1.8.4. The LCD Module is coated with a film to protect the display surface. Be care when peeling off this protective film since static electricity may be generated.

### 11.2 Storage Precautions

11.2.1. When storing the LCD modules, avoid exposure to direct sunlight or to the light of fluorescent lamps.

11.2.2. The LCD modules should be stored under the storage temperature range. If the LCD modules will be stored for a long time, the recommend condition is:

Temperature : 0°C ~ 40°C      Relatively humidity: ≤80%

11.2.3. The LCD modules should be stored in the room without acid, alkali and harmful gas.

### 11.3 Transportation Precautions

The LCD modules should be no falling and violent shocking during transportation, and also should avoid excessive press, water, damp and sunshine.