



CERT. No. QAC0946535 (ISO9001) CERT. No. HKG002005 (ISO14001)

# Product Specification

Customer: \_\_\_\_\_

Model Name: Z070TN92

Date: \_\_\_\_\_

Version: \_\_\_\_\_

Preliminary Specification

Final Specification

### For Customer's Acceptance

Approved by	Comment

Approved by	Reviewed by	Prepared by



---

## Table of Contents

1. Record of Revision .....	3
2 General Specifications.....	4
3 Input/Output Terminals .....	5
4 Absolute Maximum Ratings .....	8
5 Electrical Characteristics .....	9
6 Optical Characteristics .....	13
7 Environmental / Reliability Tests.....	16
8 Mechanical Drawing .....	17
9 Packing.....	18
10 Precautions For Use of LCD modules.....	19



**1. Record of Revision**

Rev	Issued Date	Description	Editor
1.0	2013/7/31	First Release.	Li Tang



## 2 General Specifications

	Feature	Spec
Characteristics	Size	7 inch
	Resolution	800(horizontal)*480(Vertical)
	Interface	24-bit RGB
	Connect type	Connector
	Color Depth	16.7M
	Technology type	a-Si
	Display Spec. Pixel pitch (mm)	0.1926 x 0.1790
	Pixel Configuration	R.G.B. Vertical Stripe
	Display Mode	Normally White
	Driver IC	-
	Surface Treatment	HC
	Viewing Direction	12 O'clock
	Gray Viewing Direction	6 O'clock
Mechanical	LCM (W x H x D) (mm)	164.9*100.0*5.7
	Active Area(mm)	154.08 x 85.92
	With /Without TSP	Without TSP
	Weight (g)	TBD
	LED Numbers	18 LEDs

Note 1: Viewing direction is follow the data which measured by optics equipment.

Note 2: Requirements on Environmental Protection: RoHS

Note 3: LCM weight tolerance: +/- 5%



### 3 Input/Output Terminals

No.	Symbol	Description
1, 2	VLED+	Power for LED backlight (Anode)
3, 4	VLED-	Power for LED backlight (Cathode)
5	GND	Power Ground
6	VCOM	Common voltage
7	DVDD	Power for Digital Circuit
8	MODE	DE/SYNC mode select <span style="float: right;">Note1</span>
9	DE	Data Enable
10	VS	Vertical sync signal
11	HS	Horizontal sync Signal
12	B7	Blue data(MSB)
13	B6	Blue data
14	B5	Blue data
15	B4	Blue data
16	B3	Blue data
17	B2	Blue data
18	B1	Blue data <span style="float: right;">Note2</span>
19	B0	Blue data(LSB) <span style="float: right;">Note2</span>
20	G7	Green data(MSB)
21	G6	Green data
22	G5	Green data
23	G4	Green data
24	G3	Green data
25	G2	Green data
26	G1	Green data <span style="float: right;">Note2</span>
27	G0	Green data (LSB) <span style="float: right;">Note2</span>
28	R7	Red Data(MSB) <span style="float: right;">Note2</span>
29	R6	Red Data
30	R5	Red Data
31	R4	Red Data
32	R3	Red Data
33	R2	Red Data



34	R1	Red Data	Note2
35	R0	Red Data(LSB)	Note2
36	GND	Power Ground	
37	DCLK	Pixel clock	Note3
38	GND	Power Ground	
39	L/R	Left/right selection	Note4/5
40	U/D	up/down selection	Note4/5
41	VGH	Gate ON Voltage	
42	VGL	Gate OFF Voltage	
43	AVDD	Power for Analog Circuit	
44	RESET	Global reset pin	Note6
45	NC	NO connection	
46	Vcom	Common Voltage	
47	DITHB	Dithering function	Note7
48	GND	Power Ground	
49	NC	NO connection	
50	NC	NO connection	

**Note 1:** DE/SYNC mode select. Normally pull high.

When select DE mode, MODE="1", VS and HS must pull high.

When select SYNC mode, MODE="0", DE must be grounded.

**Note 2:** When input 18 bits RGB data, the two low bits of R,G and B data must be grounded.

**Note 3:** Data shall be latched at the falling edge of DCLK.

**Note 4:** Selection of scanning mode

Setting of scan control input		Scanning direction
U/D	L/R	
GND	DV <sub>DD</sub>	Up to down, left to right
DV <sub>DD</sub>	GND	Down to up, right to left
GND	GND	Up to down, right to left
DV <sub>DD</sub>	DV <sub>DD</sub>	Down to up, left to right

**Note 5:** Definition of scanning direction.

Refer to the figure as below:

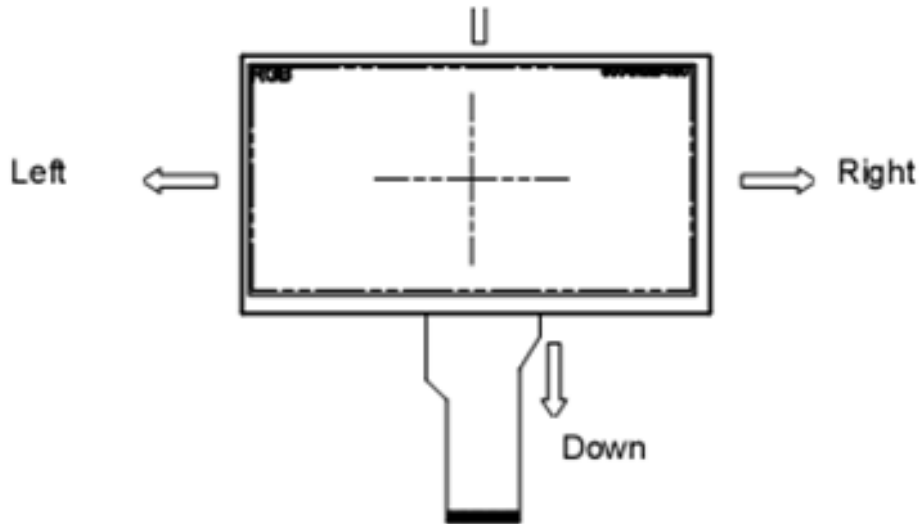

Note 6: Global reset pin. Active low to enter reset state. Suggest to connect with an RC reset circuit for stability. Normally pull high.

Note 7: Dithering function enable control, normally pull high.  
When DITHB="1",Disable internal dithering function,  
When DITHB="0",Enable internal dithering function,

Note 8: Reserve for LED power input.



#### 4 Absolute Maximum Ratings

(Note 1)

Item	Symbol	Values		Unit	Remark
		Min.	Max.		
Power voltage	DV <sub>DD</sub>	-0.3	5.0	V	
	AV <sub>DD</sub>	6.5	13.5	V	
	V <sub>GH</sub>	-0.3	40.0	V	
	V <sub>GL</sub>	-20.0	0.3	V	
	V <sub>GH</sub> -V <sub>GL</sub>	-	40.0	V	
Operation Temperature	T <sub>OP</sub>	-20	70	°C	
Storage Temperature	T <sub>ST</sub>	-30	80	°C	

Note 1: The absolute maximum rating values of this product are not allowed to be exceeded at any times. Should a module be used with any of the absolute maximum ratings exceeded, the characteristics of the module may not be recovered, or in an extreme case, the module may be permanently destroyed.





## 5 Electrical Characteristics

### 5.1 Driving TFT LCD Panel

Item	Symbol	Values			Unit	Remark
		Min.	Typ.	Max.		
Power voltage	$DV_{DD}$	3.0	3.3	3.6	V	Note 2
	$AV_{DD}$	10.2	10.4	10.6	V	
	$V_{GH}$	15.3	16.0	16.7	V	
	$V_{GL}$	-7.7	-7.0	-6.3	V	
Input signal voltage	$V_{COM}$	3.6	3.8	4.0	V	
Input logic high voltage	$V_{IH}$	0.7 $DV_{DD}$	-	$DV_{DD}$	V	Note 3
Input logic low voltage	$V_{IL}$	0	-	0.3 $DV_{DD}$	V	

- Note 1: Be sure to apply  $DV_{DD}$  and  $V_{GL}$  to the LCD first, and then apply  $V_{GH}$   
 Note 2:  $DV_{DD}$  setting should match the signals output voltage (refer to Note 3) of customer's system board.  
 Note 3: DCLK,HS,VS,RESET,U/D, L/R,DE,R0~R7,G0~G7,B0~B7,MODE,DITHB.

Item	Symbol	Values			Unit	Remark
		Min.	Typ.	Max.		
Current for Driver	$I_{GH}$	-	0.2	1.0	mA	$V_{GH} = 16.0V$
	$I_{GL}$	-	0.2	1.0	mA	$V_{GL} = -7.0V$
	$IDV_{DD}$	-	4.0	10	mA	$DV_{DD} = 3.3V$
	$IAV_{DD}$	-	20	50	mA	$AV_{DD} = 10.4V$



### 5.2.1 Interface Timing

Item	Symbol	Values			Unit	Remark
		Min.	Typ.	Max.		
HS setup time	$T_{hst}$	8	-	-	ns	
HS hold time	$T_{hhd}$	8	-	-	ns	
VS setup time	$T_{vst}$	8	-	-	ns	
VS hold time	$T_{vhd}$	8	-	-	ns	
Data setup time	$T_{dsu}$	8	-	-	ns	
Data hole time	$T_{dhd}$	8	-	-	ns	
DE setup time	$T_{esu}$	8	-	-	ns	
DE hole time	$T_{ehd}$	8	-	-	ns	
DV <sub>DD</sub> Power On Slew rate	$T_{POR}$	-	-	20	ms	From 0 to 90% DV <sub>DD</sub>
RESET pulse width	$T_{Rst}$	1	-	-	ms	
DCLK cycle time	$T_{coh}$	20	-	-	ns	
DCLK pulse duty	$T_{cwh}$	40	50	60	%	

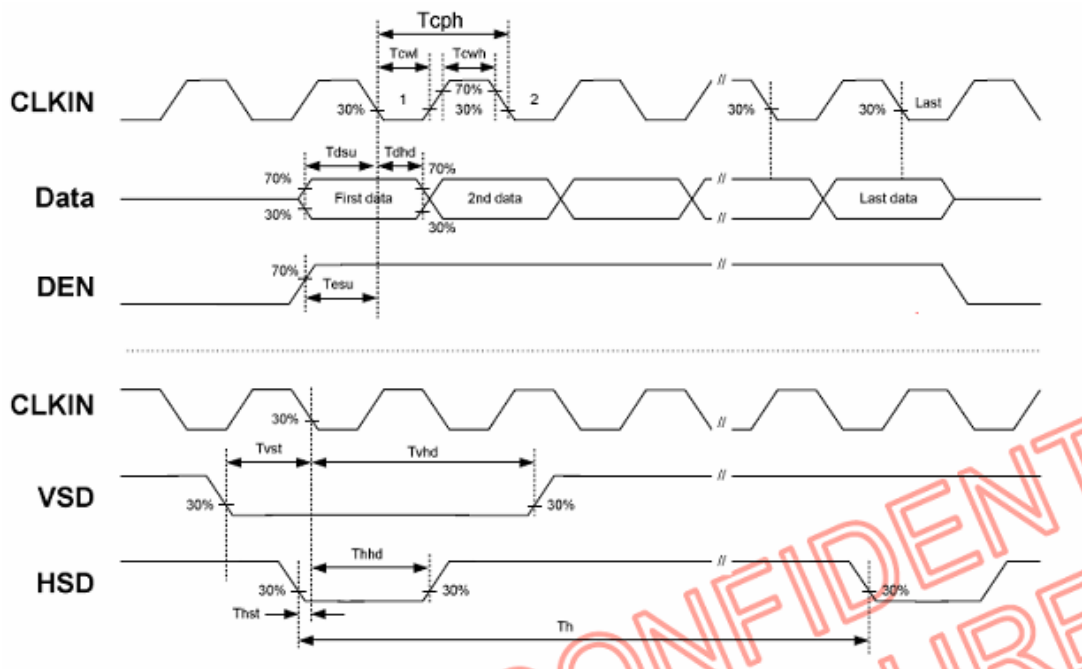



### 5.2.2 Recommended Timing Setting of TCON

TCON (Embedded In Source IC ) Input Timing (DCLK, HSD, VSD, ED)

Item	Symbol	Values			Unit	Remark
		Min.	Typ.	Max.		
Horizontal Display Area	thd	-	800	-	DCLK	
DCLK Frequency	fclk	26.4	33.3	46.8	MHz	
One Horizontal Line	th	862	1056	1200	DCLK	
HS pulse width	thpw	1	-	40	DCLK	
HS Blanking	thb	46	46	46	DCLK	
HS Front Porch	thfp	16	210	354	DCLK	

Item	Symbol	Values			Unit	Remark
		Min.	Typ.	Max.		
Vertical Display Area	tvd	-	480	-	TH	
VS period time	tv	510	525	650	TH	
VS pulse width	tvpw	1	-	20	TH	
VS Blanking	tvb	23	23	23	TH	
VS Front Porch	tvfp	7	22	147	TH	

### 5.3 Driving Backlight

Item	Symbol	MIN	TYP	MAX	Unit	Remark
Forward Current	$I_F$	-	120	-	mA	
Forward Voltage	$V_F$	9.0	9.8	10.6	V	
Backlight Power consumption	$W_{BL}$	-	TBD	-	W	

Note 1: Each LED :  $I_F = 20\text{ mA}$ ,  $V_F = 3.2\text{V}$ .

Note 2: Optical performance should be evaluated at  $T_a = 25^\circ\text{C}$  only.

Note 3: If LED is driven by high current, high ambient temperature & humidity condition. The life time of LED will be reduced. Operating life means brightness goes down to 50% initial brightness. Typical operating life time is estimated data.

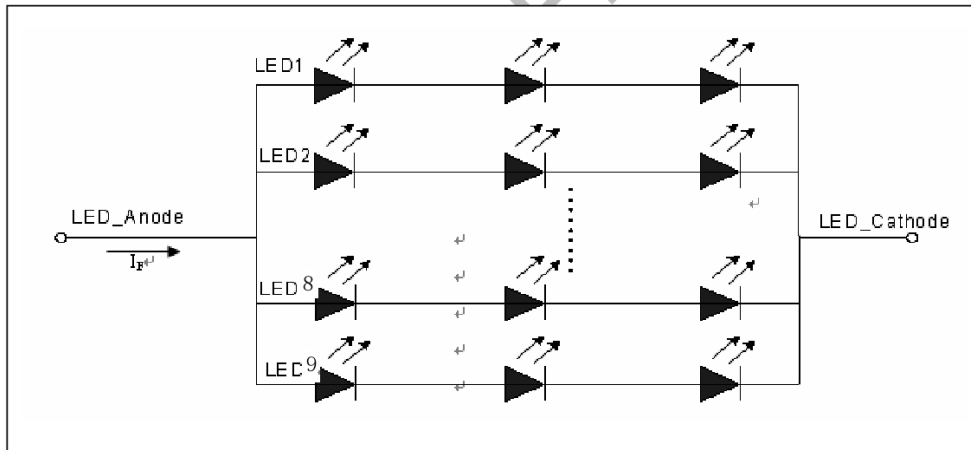

Figure : LED connection of backlight



## 6 Optical Characteristics

Items		Symbol	Condition	Min.	Typ.	Max.	Unit	Remark
Viewing angles		$\theta_L$		60	70	-	Degree.	Note2
		$\theta_R$		60	70	-		
		$\theta_T$		40	50	-		
		$\theta_B$		60	70	-		
Contrast Ratio		CR	$\Theta = 0$	-	400	500	-	Note1, Note3
Response Time		$T_{ON}$	$25^\circ C$	-	10	20	ms	Note1, Note4
		$T_{OFF}$		-	15	30		
Chromaticity	White	$X_W$	Normal $\Theta = 0^\circ$	0.26	0.31	0.36	-	Note1, Note5
		$Y_W$		0.28	0.33	0.38	-	
Color Gamut		NTSC		-	50	-	%	Note1, Note6
Luminance		$L$			200	250		

**Test Conditions:**

1.  $V_{DD}=3.3V$ , the ambient temperature is  $25^\circ C$ .
2. The test systems refer to Note 1 and Note 2.

Note 1: Definition of optical measurement system.

The optical characteristics should be measured in dark room. After 5 minutes operation, the optical properties are measured at the center point of the LCD screen. All input terminals LCD panel must be ground when measuring the center area of the panel.

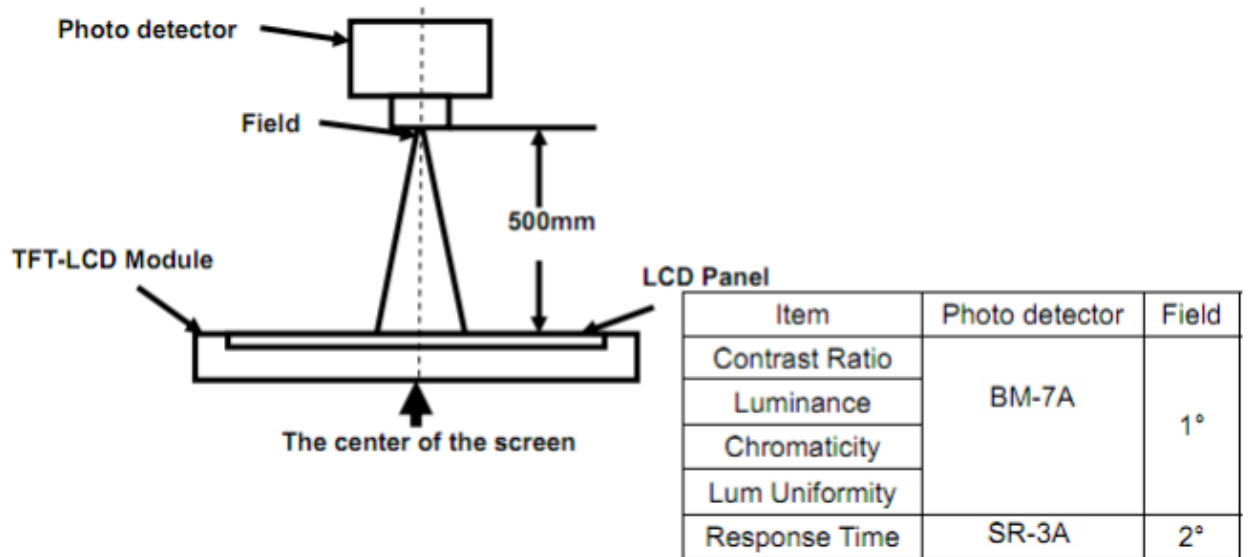

Note 2: Definition of viewing angle range and measurement system.  
viewing angle is measured at the center point of the LCD by CONOSCOPE(ergo-80).

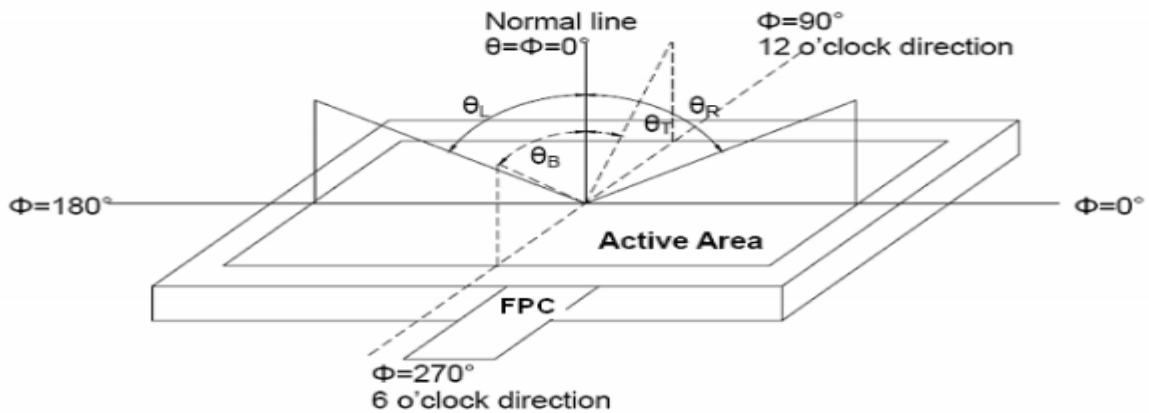

Fig. 1 Definition of viewing angle

Note 3: Definition of contrast ratio

$$\text{Contrast ratio (CR)} = \frac{\text{Luminance measured when LCD is on the "White" state}}{\text{Luminance measured when LCD is on the "Black" state}}$$

Note 4: Definition of Response time

The response time is defined as the LCD optical switching time interval between "White" state and "Black" state. Rise time (TON) is the time between photo detector output intensity changed from 90% to 10%. And fall time (TOFF) is the time between photo detector output intensity changed from 10% to 90%.

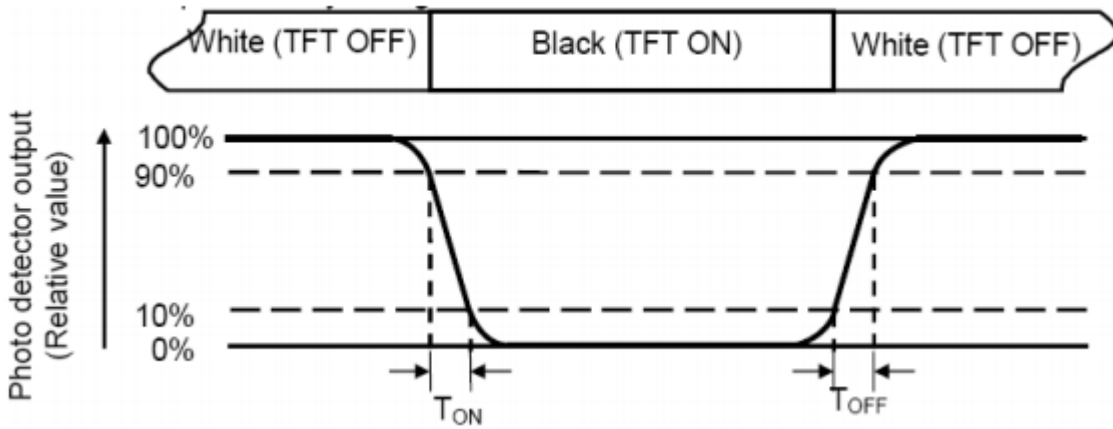

Note 5: Definition of color chromaticity (CIE1931)

Color coordinates measured at center point of LCD.

Note 6: Definition of Luminance Uniformity

Active area is divided into 9 measuring areas (Refer Fig. 2). Every measuring point is placed at the center of each measuring area.

Luminance Uniformity(U) =  $L_{min} / L_{max} \times 100\%$

L-----Active area length W----- Active area width

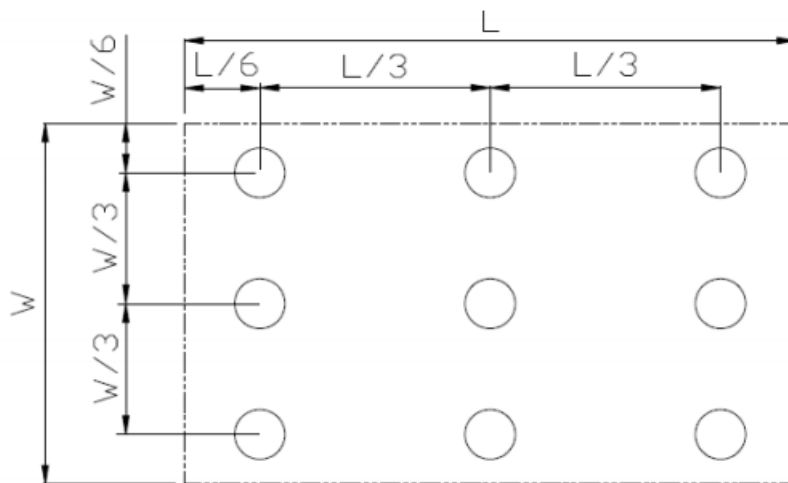

Fig. 2 Definition of uniformity

$L_{max}$ : The measured maximum luminance of all measurement position.

$L_{min}$ : The measured minimum luminance of all measurement position.

Note 7: Definition of Luminance :

Measure the luminance of white state at center point.



## 7 Environmental / Reliability Tests

No	Test Item	Condition	Remarks
1	High Temperature Opeartion	T <sub>s</sub> = +70°C, 240hrs	Note 1 IEC60068-2-2, GB2423. 2-89
2	Low Temperature Opeartion	T <sub>a</sub> = -20°C, 240hrs	Note 2 IEC60068-2-1 GB2423.1-89
3	High Temperature Storage	T <sub>a</sub> = +80°C, 240hrs	IEC60068-2-2 GB2423. 2-89
4	Low Temperature Storage	T <sub>a</sub> = -30°C, 240hrs	IEC60068-2-1 GB/T2423.1-89
5	High Temperature & Humidity Storage	T <sub>a</sub> = +60°C, 90% RH max, 160 hours	IEC60068-2-3 GB/T2423.3-2006
6	Thermal Shock (Non-operation)	-30°C 30 min ~ +80°C 30 min Change time: 5min, 30 Cycle	Start with cold temperature,end with high temperature IEC60068-2-14, GB2423.22-87
7	Electro Static Discharge (Opeartion)	C=150pF, R=330 Ω, 5 points/panel Air: ±8KV, 5 times; Contact: ±4KV, 5 times; (Environment: 15°C ~ 35°C, 30% ~ 60%, 86Kpa ~ 106Kpa)	IEC61000-4-2 GB/T17626.2-1998
8	Vibration (Non-operation)	Frequency range: 10~55Hz, Stroke: 1.mm Sweep: 10Hz~55Hz~10Hz 2 hours for each direction of X .Y. Z. (package condition)	IEC60068-2-6 GB/T2423.5-1995
9	Shock (Non-operation)	60G 6ms, ± X, ±Y , ± Z 3 times for each direction	IEC60068-2-27 GB/T2423.5-1995
10	Package Drop Test	Height: 80 cm, 1 corner, 3 edges, 6 surfaces	IEC60068-2-32 GB/T2423.8-1995

Note: 1. T<sub>s</sub> is the temperature of panel's surface.  
2. T<sub>a</sub> is the ambient temperature of sample.



## 8 Mechanical Drawing

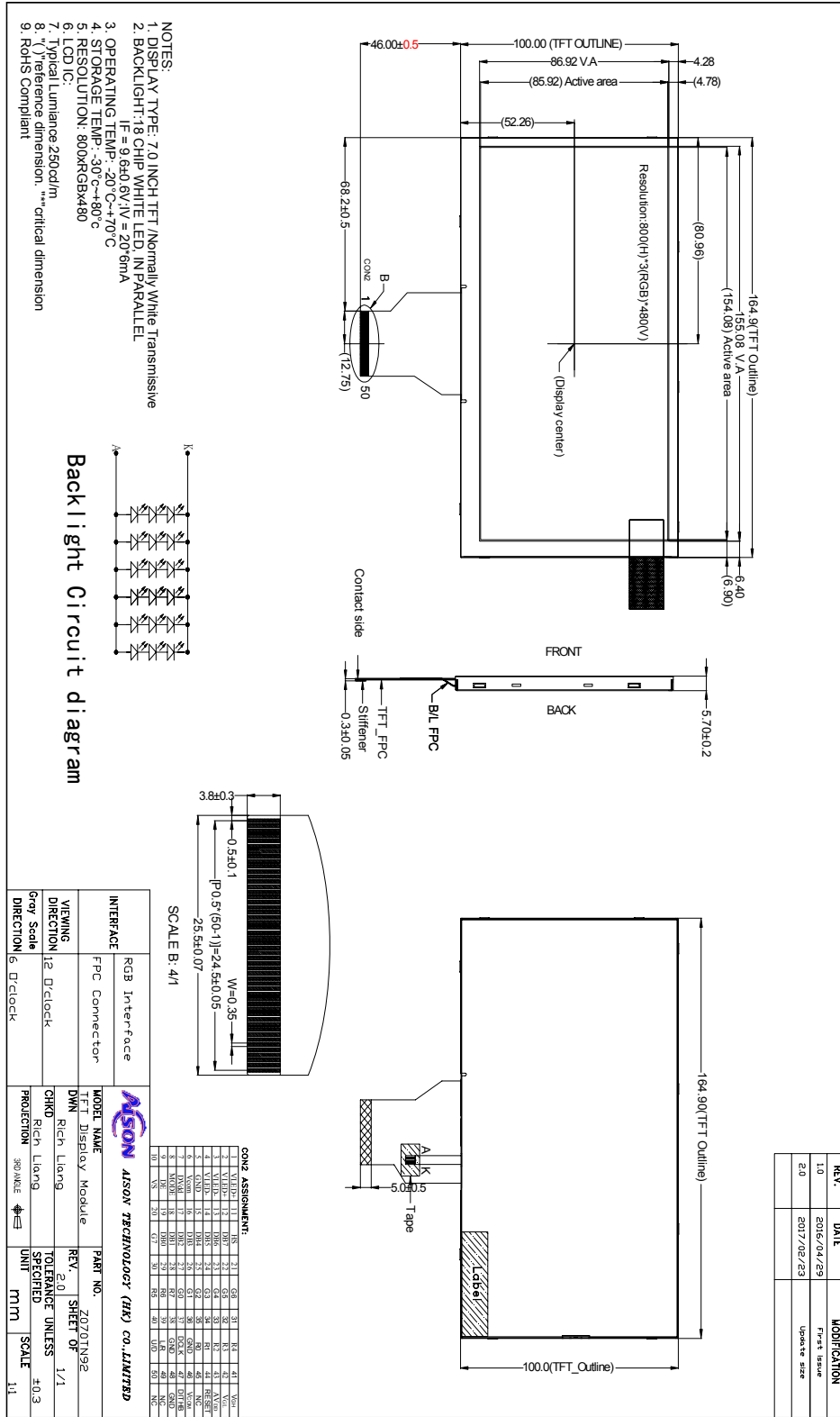

- NOTES:**
1. DISPLAY TYPE: 7.0 INCH TFT (Normally White Transmissive)
  2. BACKLIGHT: 18 CHIP WHITE LED (IN PARALLEL)  
IF = 9.6±0.6V, IV = 20.9mA
  3. OPERATING TEMP: -30°C~+70°C
  4. STORAGE TEMP: -30°C~+80°C
  5. RESOLUTION: 800KRGBx480
  6. LCD IC:
  7. Typical Luminance 250cd/m<sup>2</sup>
  8. ( ) reference dimension; \* critical dimension
  9. RoHS Compliant

**Backlight Circuit diagram**

INTERFACE	FPC Connector	RGB Interface
VIEWING DIRECTION	12 O'clock	
Grey Scale DIRECTION	6 O'clock	
MODEL NAME	TFT Display Module	PART NO.
DWN	Rich Liang	REV.
CHKD	Rich Liang	SHEET OF
PROTECTION	300 N/A	TOLERANCE UNLESS SPECIFIED
		UNIT
		SCALE
		1:1

**CONZ ASSIGNMENT:**

NO.	CONZ	DESCRIPTION	REV.	DATE
1	CONZ	CONZ	1	2016/04/29
2	CONZ	CONZ	1	2016/04/29
3	CONZ	CONZ	1	2016/04/29
4	CONZ	CONZ	1	2016/04/29
5	CONZ	CONZ	1	2016/04/29
6	CONZ	CONZ	1	2016/04/29
7	CONZ	CONZ	1	2016/04/29
8	CONZ	CONZ	1	2016/04/29
9	CONZ	CONZ	1	2016/04/29
10	CONZ	CONZ	1	2016/04/29
11	CONZ	CONZ	1	2016/04/29
12	CONZ	CONZ	1	2016/04/29
13	CONZ	CONZ	1	2016/04/29
14	CONZ	CONZ	1	2016/04/29
15	CONZ	CONZ	1	2016/04/29
16	CONZ	CONZ	1	2016/04/29
17	CONZ	CONZ	1	2016/04/29
18	CONZ	CONZ	1	2016/04/29
19	CONZ	CONZ	1	2016/04/29
20	CONZ	CONZ	1	2016/04/29
21	CONZ	CONZ	1	2016/04/29
22	CONZ	CONZ	1	2016/04/29
23	CONZ	CONZ	1	2016/04/29
24	CONZ	CONZ	1	2016/04/29
25	CONZ	CONZ	1	2016/04/29
26	CONZ	CONZ	1	2016/04/29
27	CONZ	CONZ	1	2016/04/29
28	CONZ	CONZ	1	2016/04/29
29	CONZ	CONZ	1	2016/04/29
30	CONZ	CONZ	1	2016/04/29

REV.	DATE	MODIFICATION
1.0	2016/04/29	First Issue
2.0	2017/02/23	Update size

## 9 Packing

### Packing Method

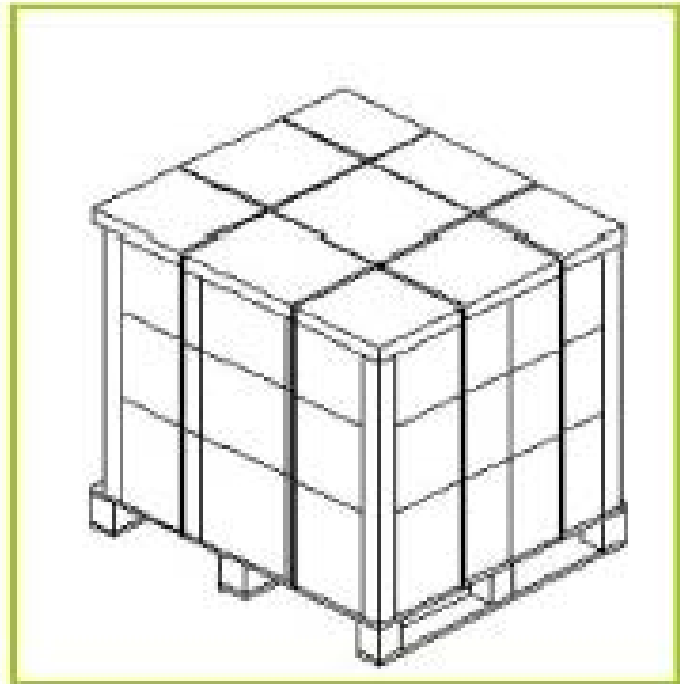
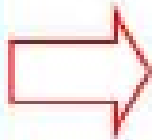
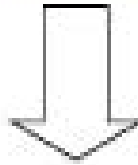



## 10. Precautions for Use of LCD modules

### 10.1 Handling Precautions

10.1.1. The display panel is made of glass. Do not subject it to a mechanical shock by dropping it from a high place, etc.

10.1.2. If the display panel is damaged and the liquid crystal substance inside it leaks out, be sure not to get any in your mouth, if the substance comes into contact with your skin or clothes, promptly wash it off using soap and water.

10.1.3. Do not apply excessive force to the display surface or the adjoining areas since this may cause the color tone to vary.

10.1.4. The polarizer covering the display surface of the LCD module is soft and easily scratched. Handle this polarizer carefully.

10.1.5. If the display surface is contaminated, breathe on the surface and gently wipe it with a soft dry cloth. If still not completely clear, moisten cloth with one of the following solvents:

- Isopropyl alcohol
- Ethyl alcohol

Solvents other than those mentioned above may damage the polarizer. Especially, do not use the following:

- Water
- Ketone
- Aromatic solvents

10.1.6. Do not attempt to disassemble the LCD Module.

10.1.7. If the logic circuit power is off, do not apply the input signals.

10.1.8. To prevent destruction of the elements by static electricity, be careful to maintain an optimum work environment.

10.1.8.1. Be sure to ground the body when handling the LCD Modules.

10.1.8.2. Tools required for assembly, such as soldering irons, must be properly ground.

10.1.8.3. To reduce the amount of static electricity generated, do not conduct assembly and other work under dry conditions.

10.1.8.4. The LCD Module is coated with a film to protect the display surface. Be care when peeling off this protective film since static electricity may be generated.

### 10.2 Storage Precautions

10.2.1. When storing the LCD modules, avoid exposure to direct sunlight or to the light of fluorescent lamps.

10.2.2. The LCD modules should be stored under the storage temperature range. If the LCD modules will be stored for a long time, the recommend condition is:

Temperature : 0°C ~ 40°C      Relatively humidity: ≤80%

10.2.3. The LCD modules should be stored in the room without acid, alkali and harmful gas.

### 10.3 Transportation Precautions

The LCD modules should be no falling and violent shocking during transportation, and also should avoid excessive press, water, damp and sunshine.